

Temperature sensor type CT T1

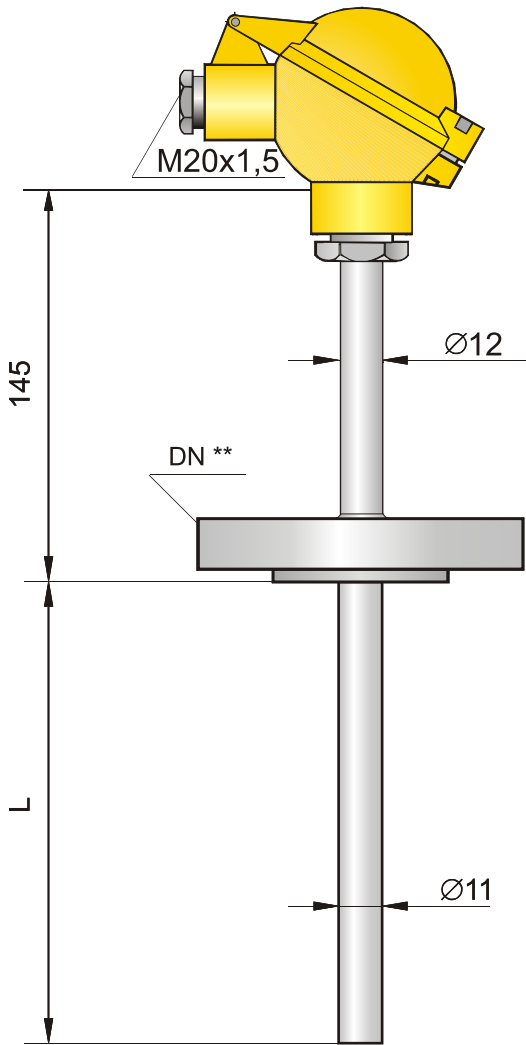

TECHNICAL DATA:

1. Measuring range:
Pt: -200 ... 550 [°C]
J/K: -200 ... 550 [°C]
2. Admissible load:
see **Graph 3** (page 126)
3. Material of wetted parts:
304ss, Inconel.
4. Standard immersion length L:
100, 160, 250, 400 [mm] (*)
5. Flange process connection
6. Time constant:

Pt	T _{0.5} [s]	T _{0.9} [s]
	≤ 40	≤ 120

J/K	Isolated junction		Grounded junction	
	T _{0.5} [s]	T _{0.9} [s]	T _{0.5} [s]	T _{0.9} [s]
	≤ 27	≤ 90	≤ 6	≤ 15

7. Diameter of the measuring insert:
Ø = 6 [mm]
8. Minimal immersion depth:
Pt: 100 [mm]
J/K: 70 [mm]

Ordering procedure:

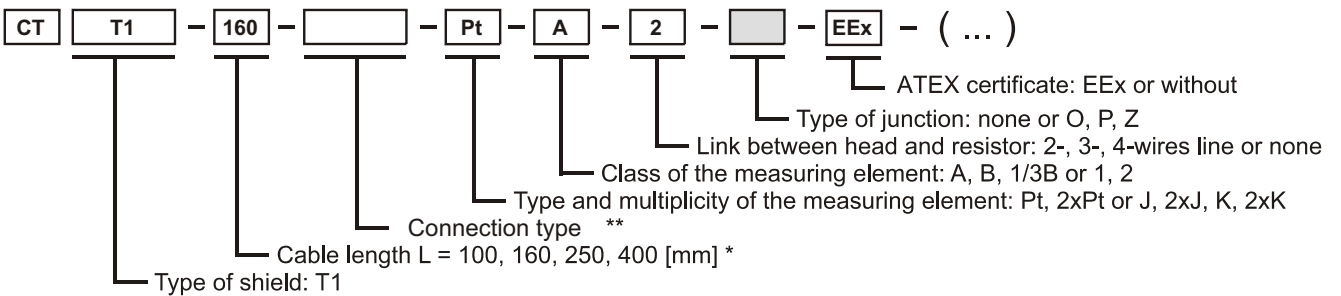

ADDITIONAL INFORMATION:

- 1.* Non-standard length of temperature sensors on demand.
2. Type of exchangeable insert: W1, W3.
- 3.**On demand, the flange of the measuring sensor T1 can be performed acc. to PN, ANSI or DIN and have different dimensions than indicated in the picture.
4. To specify temperature sensor with the head - mounted transmitter please add code of transmitter at the end of ordering code of sensor (see chapter X) e.g.

CT T1 - 160 - DN50 - Pt - A - 2 - [] - [] - (GI-22-2/0 ÷ 500/23mA)